

AW-A

Air Handling Make-Up Air Series

MANUAL – INSTALLATION, OPERATION AND MAINTENANCE

AW-A

Table of Contents

Overview

General Safety Information.....	1
Safety Notices.....	1
Unit Description.....	2
Unit Nameplate.....	2
Unit Inspection.....	2

Installation Instructions

Mechanical Installation.....	3
Electrical Installation.....	7
Hot Water and Chilled Water Coil Connections.....	11
Installation Checklist.....	13
Supply Fan Start-Up.....	15
Typical Sequence of Operation.....	17
BMS Points List.....	18

Maintenance

Maintenance.....	22
Service and Warranty Procedure.....	23
AW-A Start-Up Report.....	24
Quality Assurance Report.....	30
Limited Warranty.....	31

Appendices

Appendix A: Assembly of Split Units.....	32
--	----



Fire or Explosion Hazard

Failure to follow safety warning exactly could result in serious injury, death or property damage.

Be sure to read and understand the installation, operation and service instructions in this manual.

Improper installation, adjustment alteration, service or maintenance can cause serious injury, death or property damage.

- Do not store or use gasoline or other flammable vapors and liquids in the vicinity of this or any other appliance.

MANUFACTURED BY ▼

SolutionAir Group
404 Egesz Street
Winnipeg, MB R2R 1X5



Overview

General Safety Information

This manual provides information on installation, start-up and maintenance for an air handling unit. Improper installation can lead to unsatisfactory operation or dangerous situations. This unit should only be installed and maintained by qualified personnel. Qualified personnel should have a clear understanding of the contents of this manual prior to installation. Improper installation may lead to electric shock, possible injury from contact with moving parts and/or possible burns from contact with heating components. Additional safety concerns can arise from unit location such as a roof or inclement weather (outdoor installations). Additional safety precautions may be required.

Installer shall follow all national and local electrical code requirements such as the National Electrical Code (NEC) and the Canadian Electrical Code (CEC) in Canada. Where applicable, follow National Fire Protection Association (NFPA) requirements. The appliance must be electrically grounded in accordance with local codes or, in the absence of local codes, with the National Electrical Code, ANSI/NFPA 70, and /or the Canadian Electrical Code, CSA C22.1, if an external electrical source is utilized. The appliance installation shall conform to local building codes.

WARNING ▾

The manufacturer's warranty does not cover any damage or defect caused by modifications to the unit including unauthorized attachments of other components. Such activity may lead to unsatisfactory performance and may endanger life and property.

NOTE: This document is customer property and must be retained by the unit's owner for use by maintenance personnel.

Safety Notices

Throughout this manual Caution and Warning notices are used where additional safety information may be required. Warnings are provided to alert personnel of a potential situation that could result in personal injury or death. Cautions are provided to alert personnel of a potential situation that could result in personal injury.

In addition to Warnings and Cautions, Notices are used to indicate a situation that may result in property damage.

WARNING ▾

Indicates a potential situation that, if not avoided, could lead to serious personal injury or death.

CAUTION ▾

Indicates a potential situation that, if not avoided, could lead to minor or moderate personal injury. Cautions may also be used to indicate unsafe practices.

NOTICE: Indicates a situation or action that may cause damage to the unit or the facility.

Overview

Unit Description

The AW-A model is air handling unit gas heating unit. The unit can be either indoor or outdoor and may include supplemental cooling and/or energy recovery.

A: Unit Model

B: Number of supply fans

- 1 = One supply fan
- 2 = Two supply fans

C: Nominal fan size

D: Nominal heating capacity in kBtu/h

E: Cooling type

- AC = Air cooled
- WC = Water cooled
- EC = Evaporatively cooled

F: Refrigeration design

- DX = Cooling
- HP = Heat pump

G: Nominal cooling capacity in tons. This is based on nominal condensing unit model.

H: Cooling efficiency

- S = Standard efficiency
- H = High efficiency

I: Single path heat recovery

- Blank = None
- HR = Heat Recovery

Unit Nameplate

Figure 1 shows a typical nameplate for an AW-A unit. The nameplate is generally located in the gas train weather housing. The nameplate includes model number, serial number, electrical characteristics and other pertinent data.

Unit Inspection

This unit has been inspected and test fired prior to shipment to make sure the unit is free from defects from the manufacturer. It is possible that damage may occur during shipping, rigging and installation.

Upon receiving the unit, check that all items have been delivered by comparing the Bill of Lading to the equipment received. If anything is missing or damaged, notify the carrier immediately. The carrier should note this on the packing slip or other form of documentation and provide a copy.



NOTE: it is a good idea to take a photograph of any possible damage for record purposes.

Check the unit model number, heater size and electrical characteristics to make sure they are correct. If there are any issues, do not proceed with the installation. Contact your sales representative.

Storage

If the unit is to be stored, take precautions to prevent condensate from forming inside the unit's electrical compartments. Make sure the equipment is protected from weather and dust from site conditions by temporarily sealing all openings to the air tunnel for outdoor units and completely covering indoor units.

FIGURE 1: TYPICAL NAMEPLATE

404 Eggers Street Wilmington, MA 01897-1365 Ph: (204) 633-4808 Fax: (204) 694-7280		 			
CSA C22 No. 238 / UL 1995 OUTDOOR/INDOOR INSTALLATION ONLY					
Type of Unit Type d'unité	Commercial / Industrial Air Handler Unit				
Model Number Numero du modele	AW-A-1-xx-xxx-x-I/O-X-C-R	Serial Number Numero de serie	MA/S0000xxxYYMM		
Wiring Drawing No. No diagramme cablage	MA/S0000xxx-1 to X	Design Temperature Temperature modele	-40°F		
Line Voltage Regulation de Tension	000	Phase Phase	3		
Short Circuit Rating Short Circuit Note	000	Cycle Cycle	60		
Control Voltage Regulation de Tension	00	Unit MCA Unité de MCA	00		
Supply Air Volume Volume d'air d'arrivee	0,000 cfm	Unit MOCF Unité de MOCF	00		
Motor Horsepower Puissance de moteur	0 Hp	Pression statique externe E.S.P.	0,0 "W.C.		
Return Air Volume Volume d'air d'evacuation	N/A	Fan R.P.M. Tr/min du ventilateur	?		
Motor Horsepower Puissance de moteur	N/A	Pression statique externe E.S.P.	N/A		
		Fan R.P.M. Tr/min du ventilateur	N/A		
ELECTRIC HEAT CHAUFFAGE ELECTRIQUE		Coil Area Surface de bobine	0,0 ft ²		
Maximum Heating Rate Chauffage Maximum	000 kW	Temperature Rise Elevation de Temperature	000 °F		
Amp Draw Aspiration d'ampere	00,0	Modulating Stage Etage de modulation	00 kW		
Number of ON/OFF steps Nombre d'etapes (\"MARCHÉ/ARRÊT\")	0	kW per ON/OFF Stage kW par etape (\"MARCHÉ/ARRÊT\")	00,0 kW		
Coil High Air Velocity Vitesse elevee l'air de bobines	0,000 fpm	Coil Low Air Velocity Basse vitesse d'air de bobine	0,000 fpm		
Coil Width Largeur de bobine	00"	Coil Height Taille de bobine	00"		
COOLING REFROIDISSEMENT		Number of Stages Nombre de circuits	N/A		
Stage 1 Charge Charge de l'etage 1	N/A	Stage 2 Charge Charge de l'etage 2	N/A		
Stage 3 Charge Charge de l'etage 3	N/A	Condensator Fan Amps Ampères de Ventilateur a Condensateur	N/A		
Stage 1 Comp. Amps Ampères de Compresseur d'Etage 1	N/A	Stage 2 Comp. Amps Ampères de Compresseur d'Etage 2	N/A		
Refrigerant Refrigerant	N/A	Stage 3 Comp. Amps Ampères de Compresseur d'Etage 3	N/A		
		Hot Gas Bypass Contournement de Gas Chauf	N/A		
MINIMUM CLEARANCES FROM COMBUSTIBLES DISTANCES MINIMUMS DES COMBUSTIBLES					
LOCATION POSITION	TOP DESSUS	FRONT DEVANT	BACK DERRIERE	SIDES COTES	TYPE OF FLOOR MATERIAU DE SOL
UPROOF ORNF	6" - 153 mm	6" - 153 mm	6" - 153 mm	6" - 153 mm	COMBUSTIBLE
HORIZONTAL HORIZONTAL	6" - 153 mm	6" - 153 mm	6" - 153 mm	6" - 153 mm	COMBUSTIBLE
UNROOFED NONRETE	6" - 153 mm	6" - 153 mm	6" - 153 mm	6" - 153 mm	COMBUSTIBLE

Do not use the unit for temporary heat without first completing the start-up procedure. SolutionAir will not assume any responsibility for equipment damage resulting from condensate accumulation on the unit's electrical and /or mechanical components.

UNIT DESCRIPTION TABLE

A	B	C	D	E	F	G	H	I						
AW-A	-	1	10	-	XX, XXX	-	AC	DX	-	010	-	S	-	HR

Installation

Mechanical Installation

Location

AW-A units are approved for both indoor and outdoor installations. The installation must conform with local building codes.

The unit is suitable for use in aircraft hangars, parking structures and repair garages when marked and installed, as applicable, in accordance with:

Standard for Airport Hangars, ANSI/NFPA 409

Standard for Parking Structures, ANSI/NFPA 88A

Standard for Repair Garages, ANSI/NFPA 88B

No alterations are to be made on this unit.

Unit Clearances



WARNING

COMBUSTIBLE PRODUCTS: The unit must not be operated in the presence of hazardous atmospheres containing flammable vapors or combustible dust for risk of fire or explosion. The use and storage of any flammable material in the vicinity of the appliance is hazardous.

CORROSIVE PRODUCTS: The unit must not be operated in the presence of chlorinated vapors, halogenated hydrocarbons, cleaning solvents, refrigerants, swimming pool exhaust or in application with airborne substances containing silicone. When such vapor mixes with the products of combustion, highly corrosive compounds result causing premature failure of the heat exchanger and other components. In such event, the warranty is void. Exposure to these compounds can lead to personal injury or death.

Before placing the unit, clearances to combustible materials and obstructions should be considered.

Maintain minimum clearances to combustible materials as indicated as shown in **Figure 2**.

The outdoor air inlet must be designed to minimize entry of snow and rain.

Adequate building relief shall be provided so as not to over pressurize the building. This can be accomplished by taking into account, through standard engineering methods, the structure's designed/calculated infiltration/exfiltration rate, by properly sized relief openings, or by interlocking powered exhaust system.

FIGURE 2: TYPICAL UNIT CLEARANCES FOR AW-A UNITS ▼

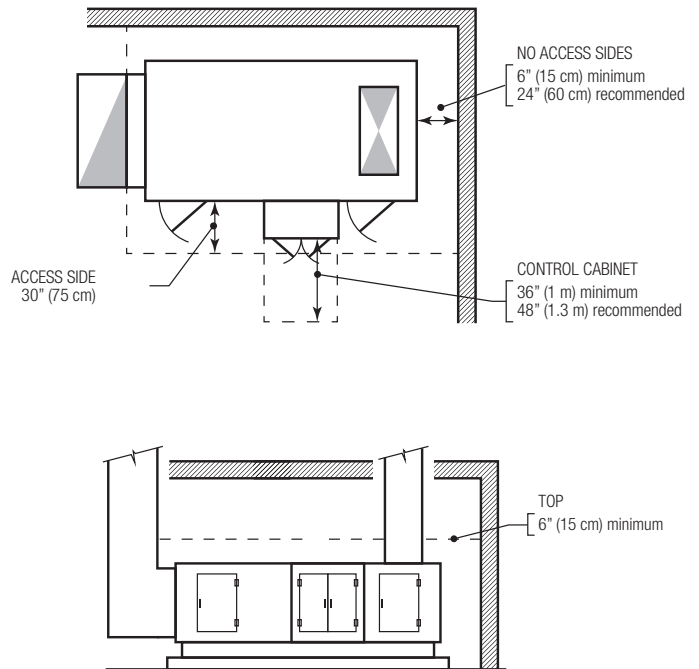

For ease of service, it is also advisable to maintain a minimum of 48" (1.2 m) clearance to the control side of the unit and 24" (60 cm) or more on the side opposite of the controls.

Roof Curb or Base

AW-A units can be installed on a concrete housekeeping pad, sleepers or a roof curb. The entire perimeter base and frame structure must be continuously supported with either field supplied sleepers or structural steel. Make sure that the sleepers or structural steel supports are the correct dimensions for the unit and that it is flat and level.

NOTICE - CONTINUOUS STRUCTURAL SUPPORT REQUIREMENT:

The unit is designed to have continuous structural support around its entire perimeter. Failure to provide continuous structural support will damage the unit and void the warranty.

AW-A

Installation

Check that the housekeeping pad is the correct dimensions for the unit and that it is flat and level. Check that there is enough trapping height and that a floor drain is nearby where the furnace condensate drain will be located.

Generally the curb is shipped in advance of the unit delivery. It should be installed along with any required ductwork prior to unit installation. Where a roof curb has been supplied in knocked-down condition, absolute care must be taken to make sure that all corners are square, and that finished dimensions exactly match those provided on the drawings. If this is not done, problems could arise with the seal of the unit to the curb.

Check diagonal dimensions prior to securing the curb to ensure that dimensional integrity has been maintained during shipping. Shim the curb to the deck as required and complete roofing in accordance with accepted roofing practices.

Prior to the installation of the unit, check that the curb is the correct dimensions for the unit and that the curb profile is correct (this is especially important if the curb is not supplied by SolutionAir). Check that the curb is both level and square. Curb ductwork that passes down through the curb must be installed by installing contractor prior to unit placement. Gasketing or other forms of sealant must be used around the curb perimeter and at the duct connections. When the curb is supplied by SolutionAir, a neoprene gasket is included. Prior to the installation of the unit, secure the gasket to the mating surface of the curb by peeling the backing off the gasket material and applying adhesive-side down.

NOTE: To minimize sound transmission, only cut openings in roof deck for ductwork penetrations. Do not cut out the entire roof deck within in the curb perimeter.

If the unit is elevated, a field constructed cat walk around the unit is strongly recommended to provide access for service.

FIGURE 3: CURB INSTALLATION DETAIL ▼

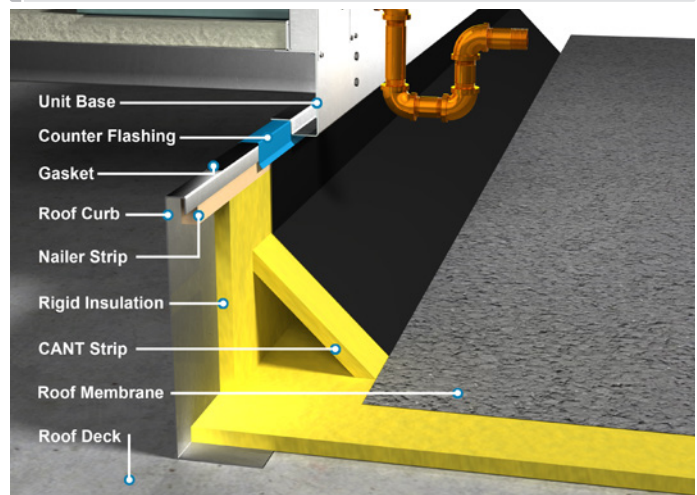

Installation

Rigging

WARNING ▼

HEAVY COMPONENTS: Never lift a unit or section in windy conditions. Use cables, chains or slings only as shown. Each cable, chain or sling must be capable of supporting the weight of the entire unit or component. Adjust cable, chain or sling length for an even unit lift. Other lifting arrangements may damage unit or component. Failure to properly lift unit or component may result in death or serious injury.

All AW-A units are built on a base frame, and are designed to be lifted from this base. Each section of the unit is provided with lifting points at each corner and sometimes at intermediate points. Lifting points are typically designed as, but not limited to, those shown in Figure 5.

General rigging method should be followed in all cases:

1. Before lifting, check the unit weight to ensure that hoisting equipment is adequate size. Locate the lifting lugs as marked or shown on the unit drawing.
2. Spreader bars must be used when lifting the equipment. Care must be taken to ensure that the lifting cables do not damage the unit casing during the lifting operation. See Figure 6 for typical spreader bar arrangement.
3. If the unit is to be lifted by forklift or other lifting devices, make sure that lifting forces are exerted on the perimeter base frame NOT the floor of the unit. Lift all components to the installation site separately to avoid damage.
4. Equipment must be lifted simultaneously by all lifting points to distribute the load properly. When multiple lifting points are furnished, they are to share the weight evenly via spreader bar(s).
5. Test lift the unit to make sure it is properly rigged and balanced. Make any necessary adjustments to rigging prior to performing the full lift.
6. Unit is designed to be lifted vertically.
7. For some models the unit may be shipped in multiple sections. Each section is designed to be lifted separately.

FIGURE 4: TYPICAL LIFTING POINTS ▼

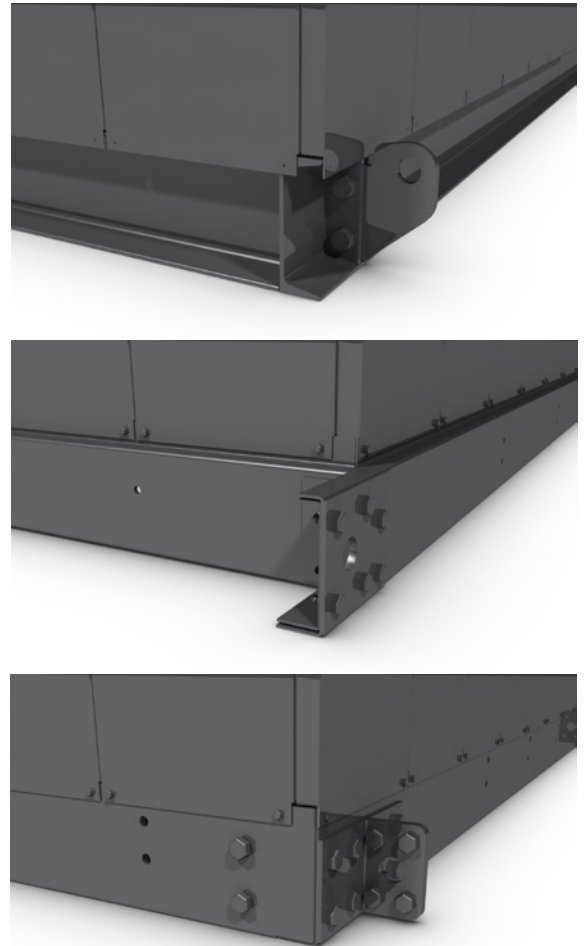
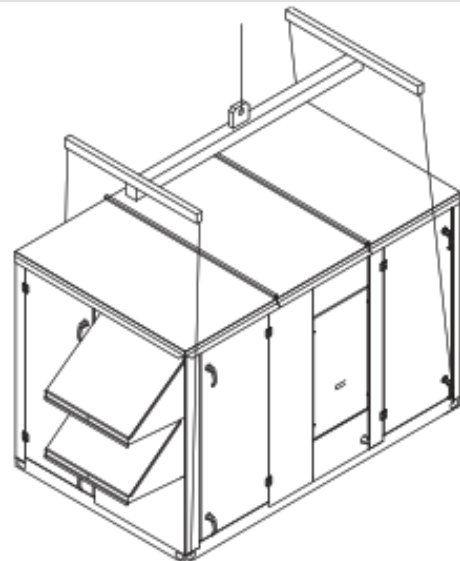

FIGURE 5: TYPICAL SPREADER BAR ARRANGEMENT ▼



Installation

Unit Assembly

WARNING ▼

HEAVY COMPONENTS: The unit sections are very heavy and significant force will need to be applied to cinch the sections together. Make sure everyone is clear of the sections prior to cinching to avoid injury.

SPLIT UNITS: AW-A units may be shipped as a single unit or in sections for field assembly by the installing contractor. For proper assembly of split units, refer to Appendix A of this manual. Failure to follow the instructions in this manual may void your warranty.

1: Split unit sections shall only be pulled together using the provisions on the base, see Figure 7. Trying to pull sections together from the cabinet walls or roof will damage the cabinet and void the warranty. Refer to Appendix A.

2: Where sections join together, a flanged joining strip with bolt holes is provided. Refer to Appendix A for detailed instructions on how to attach these strips and all other components needed to properly seal between the unit splits.

3: Mount any loose items such as intake hoods, see Figure 9, and secure them to the unit with self-tapping fasteners.

4: Remove all shipping braces, packing etc. from the unit, see Figure 10.

Duct Connections

On outdoor units with ducting passing down through the curb, the ducting will be installed prior to unit placement and attached to the curb. For all other duct connections, the ductwork will be connected to the unit casing using sheet metal screws by the installing contractor. Unless indicated on the submittal drawings, the weight of the ducting should not be placed directly on the unit. The installing contractor should provide an external means to carry the duct weight.

Access panels in the ducting near the unit are recommended. Where no access to the unit inlet or discharge section is provided as part of the unit (for example an access door in the unit), access panels are strongly recommended for inspection and service.

FIGURE 6: TYPICAL BASE CINCH POINTS ▼

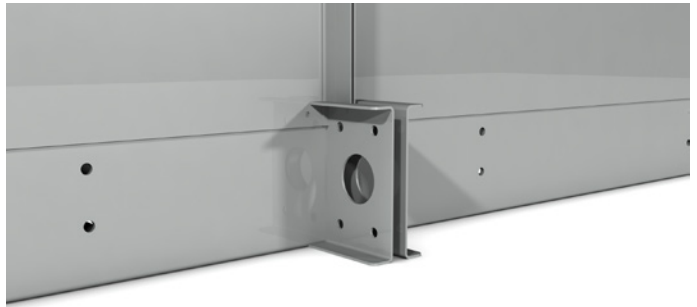

FIGURE 7: TYPICAL FLANGE JOINTS ▼

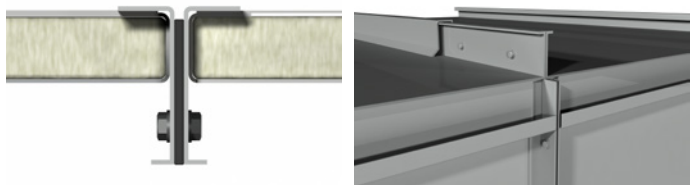

FIGURE 8: OUTDOOR AIR HOOD ▼

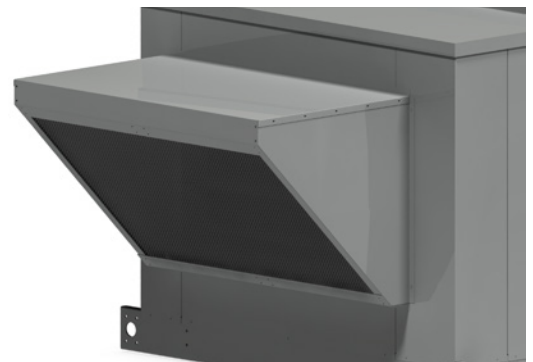

FIGURE 9: TYPICAL FAN BASE SHIPPING BRACKET ▼



Electrical Installation

WARNING ▾

ELECTRICAL SHOCK HAZARD: Disconnect all electric power, including remote disconnects before servicing. Follow proper lockout/tagout procedures to ensure the power cannot be inadvertently energized. Failure to disconnect power before servicing could result in death or serious injury.

NOTICE - USE COPPER CONDUCTORS ONLY: Unit terminals are designed for copper conductors only. Failure to use copper conductors may result in unit damage.

Main Power Connection

All connections to the unit and the main disconnect switch must conform to the Canadian Electrical Code/National Electrical Code and local codes.

1. Before proceeding with electrical connections, ensure that the unit characteristics and the intended supply match. The proper voltage for connection is listed on the rating plate attached to the unit.
2. Unit must be electrically grounded in accordance with local codes, or in the absence of local codes, with the National Electrical Code, ANSI/NFPA 70, and /or the Canadian Electrical Code, CSA C22.1, if an external electrical source is utilized.
3. Refer to the unit submittal drawing to determine the suggested location of the field wired power supply. Where a disconnect is supplied as part of the unit, the main power connection will be the line side of the disconnect.
4. If the unit is not supplied with a factory mounted disconnect, a field supplied disconnect must be installed in accordance with local codes, or in the absence of local codes, with the National Electrical Code, ANSI/NFPA 70, and /or the Canadian Electrical Code, CSA C22.1. Where a disconnect is supplied by others, the main power connection to the unit will be the line side of the main splitter block. Refer to unit electrical wiring diagrams for details.
5. Ensure that the routing of the power supply wiring does not interfere with removal of any unit access door, or in any way hinder servicing of the unit.

FIGURE 10: TYPICAL FACTORY SUPPLIED DISCONNECT ▾



FIGURE 11: TYPICAL SPLITTER BLOCK TERMINATION ▾



Installation

6. Refer to the submittals for electrical service routing. Unless indicated on the submittals, DO NOT penetrate the floor of the unit to route electrical conduits to the unit control panel. Provide a pitch pocket in accordance with standard roofing practice.
7. For units that are shipped in multiple sections, some electrical connections may have to be made by the installer in the field. Field wiring to be done by the installer appears as a dotted line on the wiring diagram. Wiring to connect two sections of a unit will be marked by the factory and a terminal block will be provided for such connections.
8. Fuses are furnished and installed by the factory in accordance with the National Electrical Code, ANSI/NFPA 70, and /or the Canadian Electrical Code, CSA C22.1. Should the replacement of any fusing become necessary, the replacement MUST be of the same amperage as the original. Failure to use equivalent replacement fuses may result in damage to components within the electrical system of the unit and/or the building. If any of the original wires need to be replaced, they must be replaced with type TEW 105° or equivalent except where noted.
9. On units with three-phase power supplies, make sure that motor rotation is correct as connected.

Auxiliary Power Connections

A separate 120/1/60 power supply may be required on units with convenience outlets and lights. Refer to unit wiring diagrams for wiring sizing details and connection points.

Controls Installation

All field wiring must be in accordance with local codes, or in the absence of local codes, with the *National Electrical Code, ANSI/NFPA 70, and /or the Canadian Electrical Code, CSA C22.1.*

Field controls wiring requirements will depend on the controls provided with the unit. A basic unit will require controls by others. Only the minimum safety controls are provided by SolutionAir. A controller or thermostat must be provided by the installing contractor. Refer to unit electrical wiring diagrams for details.

Exhaust Fan Interlock

CSA and local building codes require exhaust air interlock to ensure a burner circuit is not energized unless a comparable exhaust system is operating. Terminals for field connection of an interlocking device are provided. Refer to unit electrical wiring diagrams.

Each installation is different but several methods of

FIGURE 12: ELECTRICAL INSTALLATION W/PITCH POCKET ▼



FIGURE 13: CONVENIENCE OUTLET AND LIGHTS ▼

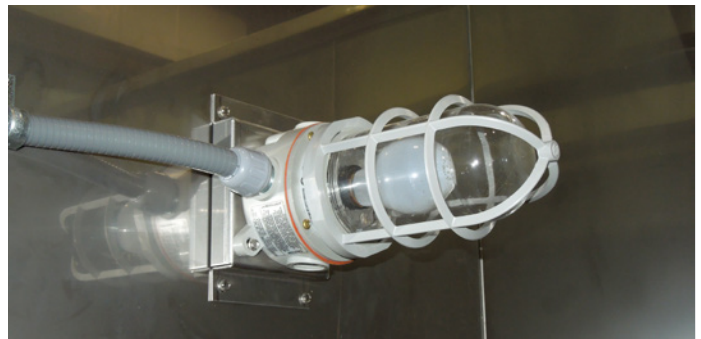

interlocking exhaust air with make-up air systems include:

- Interlock with exhaust fan motor starter
- Control wire relay in exhaust fan motor starter circuit
- Current sensing device for exhaust fan motor starter
- Air proving switch in exhaust airflow

The supply air capacity of the make-up air unit shall not exceed 10% of the exhaust airflow. Where the supply air is discharged into a booth, the exhaust air must equal the supply air of the booth. For applications where the exhaust air volume is variable, the supply air volume may need to be either 2-stage or variable flow. For these applications, the interlocks must match the level of supply air volume required.

Where the failure of this make-up air unit may lead to a malfunction of another fuel burning piece of equipment

AW-A

Installation

in the building (e.g. this unit is the make-up air unit for a boiler), the unit is to be interlocked to open the inlet air dampers or other such devices.

Units supplied with controls may require field wiring to a remote sensor or control panel. Refer to unit electrical wiring diagrams for details.

An optional space thermostat or sensor may be shipped loose for field installation. The sensor may be duct mounted and/or wall mounted.

1. Locate space sensors or thermostats where they will provide a representative reading of the space condition.
2. Avoid areas with cold drafts or in the warm supply-air stream of the unit.
3. On indoor units, do not mount the thermostat or sensor on the unit casing, as it may be affected by heat radiating off the unit.
4. Do not place near other sources of warmth, such as lamps, appliances, etc.
5. Refer to unit electrical wiring diagrams for details on how to wire the sensor to the control panel.
6. Ensure that all remote wiring is equivalent to factory installed wiring and that voltage drop does not exceed 10 percent.

An optional duct mounted discharge air temperature sensor may be shipped loose for field installation.

1. The sensor strip must be parallel to the flow of air.
2. The sensor must be mounted as close to the center of the duct as possible.
3. The sensor must be located in a straight section of the duct and must be 8-10 feet (2.4 to 3m) downstream from the supply air connection and out of direct line of sight from the heat exchanger.
4. Do not install temperature sensors near any elbows or transitions.
5. Refer to unit electrical wiring diagrams for details on how to wire the sensor to the control panel.
6. Ensure that all remote wiring is equivalent to factory installed wiring and that voltage drop does not exceed 10 percent.

An optional outdoor air temperature/humidity sensor may be shipped loose for field installation.

1. To be installed outdoors.

FIGURE 14: TYPICAL SPACE SENSOR ▼



FIGURE 15: TYPICAL DUCT MOUNTED TEMP. SENSOR ▼



Installation

An optional remote control panel may be shipped loose for field installation.

1. Locate the panel indoors where operations and maintenance have ready access.
2. Refer to unit electrical wiring diagrams for details on how to wire the sensor to the control panel.
3. Ensure that all the remote wiring is equivalent to factory installed wiring and that the voltage drop does not exceed 10 percent.

Where possible, the low limit temperature sensor is factory mounted. Some unit configurations require the sensor to be field mounted in the supply air ductwork. In this situation, the sensor and field wiring will be coiled up in the weather housing. The installing contractor shall install the sensor approximately 10 ft. (3 m) down the supply air duct.

Electric Heater



Risk of electric shock. Disconnect all supplies before working on any circuit.

NOTICE - INSTALLATION SHOULD CONFORM TO LOCAL ELECTRIC CODE: Electric installation should be done by qualified electrician and should conform to local electrical code.

NOTICE - RISK OF MALFUNCTION: Use only copper wires suitable for 105 °C (221 °F)

NOTICE - A DISCONNECT SWITCH AND/OR FUSES SHOULD BE INSTALLED ON SUPPLY: If a disconnect switch and/or fuses have not been supplied on control panel of electric heater, disconnect switch and/or fuses should be installed on supply. Installation should be done by qualified electrician and should conform to local electrical code.

NOTICE - GAUGE OF SUPPLY WIRES SHOULD CONFORM TO LOCAL ELECTRICAL CODE: Gauge of electric supply wires should be of appropriate section, function of line current, as per local electrical code.

FIGURE 16: TYPICAL REMOTE CONTROL PANEL ▼



1. Connect all wires to appropriate terminals as per electrical diagram affixed inside the control panel door.
2. Correct connection tightening should be verified before start up, and after short period of operation (typically after 2 weeks).

Hot Water and Chilled Water Coil Connections

NOTICE - IMPROPER PIPING MAY LEAD TO UNIT AND BUILDING

DAMAGE: Improper piping on hot water and chilled water coils may lead to leaks that can damage the unit and the building. Follow these instructions carefully.

NOTICE - IMPROPER FREEZE PROTECTION CAN LEAD TO UNIT AND BUILDING DAMAGE:

In climates where freezing conditions occur, some form of freeze protection must be followed to avoid coil damage and subsequent leaks that can damage the unit and the building. Damage from improper freeze protection will void the warranty.

Some units may include hot water and/or chilled water coils. Multiple coils may be stacked in the same rack. Indoor units will have the piping connections stubbed out through a removable coil access cover. Depending on the unit configuration, outdoor units will have either a vestibule or access section with a pipe chase to allow the piping to be routed into the building. Refer to the submittal drawings for piping arrangements.

1. All piping connections should be counterflow, with respect to air flow, with water entering at the bottom and leaving at the top of the coil. Confirm that the coil can be piped properly. If not, do not continue piping. Contact your sales representative.
2. Hot water and chilled water coils are generally not supplied with any piping or control valves. The installing contractor is responsible for all field piping and leakage tests.
3. Stacked coils need to be piped in parallel with reverse return piping.
4. Route properly-sized piping through the vestibule or pipe chase to the coils. Include control and isolation valves as required.
5. Use a backup wrench whenever attaching fittings to the coils. Failure to do so will damage the coils and void the warranty.
6. Leak test the unit prior to filling the system. Repair all leaks and re-test prior to filling the system.
7. Bypass coils during system flush. Failure to do so may cause debris to be caught in control valves and or the coil.

FIGURE 17: UNIT WITH CHILLED WATER COILS ▼



Cooling Device Condensate Traps

NOTICE - IMPROPER TRAPPING MAY FLOOD UNIT: Improper condensate traps may flood the unit leading to damage of both the unit and the building below. Follow the instructions below carefully.

The AW-A unit may have an optional DX, chilled water cooling coil or other condensate producing device in either the draw through (upstream of the supply fan) or blow through configuration (downstream of the supply fan) that includes a condensate pan. Devices that include a condensate pan will require a field supplied condensate trap. The height and configuration of the trap will depend on the location with respect to the supply fan and the supply fan total static pressure. Particularly in the case of a draw through trap, improper trapping may stop the condensate from draining and cause the unit to flood. This can damage both the unit and building. Traps require priming and in some situations heat tracing.

AW-A

Installation

Draw Through Trap Sizing

$H1 = \text{Supply Fan TSP} + 1 \text{ inch (2.5cm)}$

$H2 = 0.5 \times H1$

Example:

Size a condensate trap for a unit with TSP of 5 in (12.5 cm) w.c.

$H1 = 5 + 1 = 6 \text{ inches (15 cm)}$

$H2 = 0.5 \times 6 = 3 \text{ inches (7.5 cm)}$

Blow Through Trap Sizing

$H1 = \text{supply fan TSP} + 1 \text{ inch (2.5 cm)}$

$H2 = H1 - \frac{1}{2} \text{ inch (1.3 cm)}$

Example:

Size a condensate trap for a unit with TSP of 5 in (12.5 cm) w.c.

$H1 = 5 + 1 = 6 \text{ inches (15 cm)}$

$H2 = 6 - \frac{1}{2} = 5 \frac{1}{2} \text{ inches (14 cm)}$

Wash Down Drains

Some units may be supplied with wash-down drains. These allow water to drain from a periodical wash-down of the inside of the unit. It is not recommended to trap these drain connections. While it will not damage the unit, the traps would need to be constantly primed to provide a seal. The following are acceptable options:

1. Provide caps for each wash-down drain. These can be removed during the wash-down process and a hose can be attached to direct flow to a suitable floor drain (indoor applications).
2. Pipe all the wash-down drains to a suitable floor drain (indoor applications) and include a shut-off valve. The valve can be opened during the wash-down process.

FIGURE 18: COOLING COIL CONDENSATE TRAP ▼

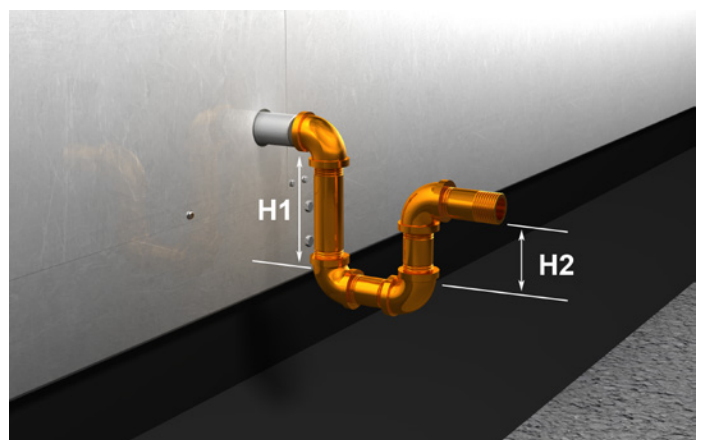
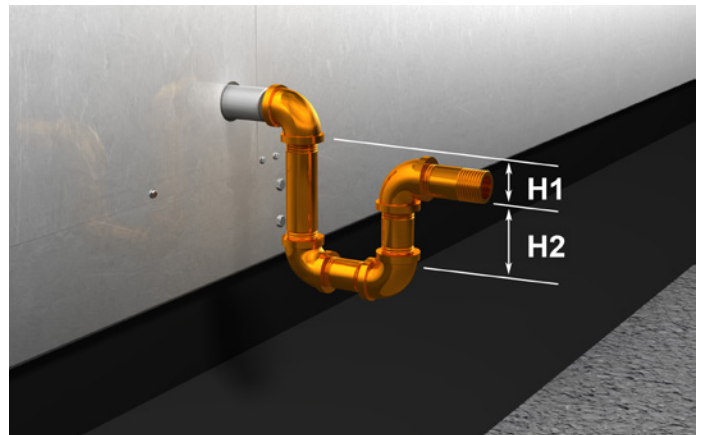
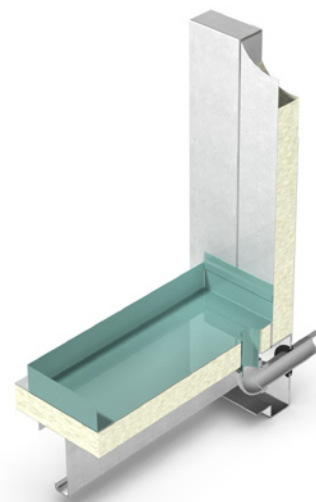

FIGURE 19: WASH-DOWN DRAIN CONNECTION ▼



Installation

Installation Checklist

The following checklist is a summary of all the steps necessary for a successful start-up. This is not intended to replace the detailed information in the applicable sections of this manual.

Task	Complete
General	
Inspect unit for freight damage or missing items on the Bill of Lading.	
Confirm the installation location meets the necessary clearances.	
Assemble and install roof curb if required.	
Install ductwork and attached to curb (for down flow units).	
Install pitch pocket for electrical supply if required.	
Set unit on curb, sleepers or housekeeping pad.	
Check that unit is level.	
Seal, bolt and cap all split joints if required.	
Remove shipping hold downs, shipping braces etc. from unit.	
Install outdoor air hoods and any other components shipped loose for field installation.	
Check all fan isolators for proper adjustment and operation.	
Install filters as required.	
Electrical Connections	
Confirm that main electrical supply matches the name plate requirements.	
Inspect control cabinets and tighten any loose connections.	
Provide disconnect if one is not factory supplied.	
Connect power supply to factory or field supplied disconnect.	
Properly ground the unit.	
Interlock unit to exhaust system	
Control Wiring Connections	
Complete controls wiring as per the wiring diagrams.	
Hot Water And Chilled Water Coil Connections	
Confirm coils can be piped correctly.	
Route properly sized piping through either the vestibule or pipe chase.	
Leak test piping.	
Install cooling device condensate drains if required.	
In cold weather climates, make sure there is some form of freeze protection.	

WARNING ▾

ELECTRICAL SHOCK HAZARD: Disconnect all electric power, including remote disconnects before servicing. Follow proper lockout/tagout procedures to ensure the power cannot be inadvertently energized. Failure to disconnect power before servicing could result in death or serious injury.

HAZARDOUS SERVICE PROCEDURES: During installation, testing, servicing and troubleshooting of this product it may be necessary to work with live electrical components and moving mechanical components. Have a qualified technician who has been properly trained in handling live electrical components perform these tasks. Failure to follow all electrical safety precautions when exposed to live electrical and mechanical components could result in death or serious injury.

In addition to the information contained in this manual, videos are available for start-up of this model at www.solutionairgroup.com.

Before Start-Up

Prior to starting the unit and with the main disconnect in the "OFF" position, make sure the following work is complete:

Pre-Start-Up Checklist	
Task	Complete
General	
All steps in installation check list are complete.	
Fan Inspection	
Shipping bolts (under fan isolators) and materials have been removed from the unit. Manually rotate fans and confirm they move freely.	
All bearing, drive, and blower set-screws have been checked for tightness.	
Drive alignments and belt tension are correct.	
Electrical	
Electrical power is acceptable (see below).	

Electrical Power Check

WARNING ▾

HAZARDOUS SERVICE PROCEDURES: During installation, testing, servicing and troubleshooting of this product, it may be necessary to work with live electrical components and moving mechanical components. Have a qualified technician who has been properly trained in handling live electrical components perform these tasks. Failure to follow all electrical safety precautions when exposed to live electrical and mechanical components could result in death or serious injury.

Prior to powering the unit, it is crucial to check the incoming electrical power as follows:

1. Check that the electrical power matches the name stated data.
2. Check that the voltage on each leg is within the stated voltage range and/or does not exceed 10% of name plate value.
3. Check that the voltage imbalance on all three phases is within 2% while unit is running.

If any of these conditions are not met, do not continue commissioning the unit. Arrange to have the power issue resolved.

Installation

Fan(s) and Compressor(s) Start-Up

WARNING ▾

HAZARDOUS ROTATING EQUIPMENT: Contact with the rotating fan, belts or motor can lead to death or severe injury. Follow proper lockout/tagout procedures to ensure the power cannot be inadvertently energized.

Once power has been checked, bump test supply fan. If the rotation is correct, continue checking rotation on all other fans and compressors. If rotation is incorrect then switch any two legs on the load side of the main disconnect. Then continue checking rotation.

1. Select "off" for the system switch or unit controller.
2. Depress the contactor manually for a moment to "bump" the fan/compressor. Check the fan/compressor rotation. There is typically an arrow on the fan housing to indicate rotation direction.
3. If the rotation is not correct, shut down the unit and turn off the power. Switch any two of the power leads at the load side of the disconnect.
4. Check the fan/compressor motor amp draw and compare it to the name plate rating or motor rating plate. If the amp draw is too high, correct the air flow and/or duct static pressure drop to reduce amp draw. If the fan speed is adjusted, make sure not to exceed the maximum fan speed rating.
5. The fan thermal overloads must be set to the appropriate motor performance after all adjustments have been made.

Sheave Alignment and Belt Tension

1. Confirm that the fan and motor shafts are parallel. If not, make adjustments.
2. Confirm that the fan and motor sheave grooves are coincident. If not, make adjustments.
3. Confirm all setscrews are tight.

Belt Tensioning

On units with belt drive fans:

1. Check belt tension. The correct tension is the lowest possible without belt slippage.
2. Check belt tension frequently during the first two days.
3. Avoid foreign materials such as oil on the belts.

FIGURE 20: SUMMER - WINTER SWITCH ▾



FIGURE 21: SHEAVE ALIGNMENT AND BELT TENSION ▾

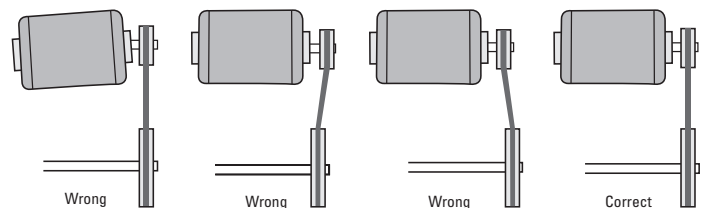

Proper alignment of motor and drive shaft

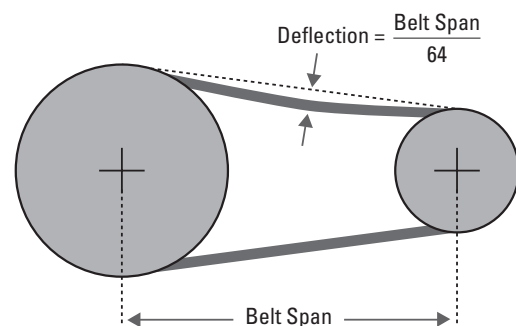

Proper fan belt tension

Installation

Air Balance

HAZARDOUS SERVICE PROCEDURES: Operating the unit outside of its design air flow range can lead to premature heat exchanger, fan and motor failure. Follow the requirements listed below. Failure to provide correct air flow through the unit will void the warranty.

Once the unit has been started, an air balance should be performed by a qualified technician.

1. Confirm that the air flow matches the design air flow indicated on the submittal documents.
2. If drive changes are made to achieve the design air flow, confirm that the supply fan motor amp draw is acceptable and the fan speed does not exceed the fan rating.
3. When the unit has a coil bypass damper, it needs to be adjusted to ensure proper air flow across coils.

Installation

Typical Sequence of Operation

SolutionAir AW-A units can be customized with a wide variety of controls options. The following is a typical sequence for a basic make-up air unit. Refer to the submittal for specific sequence of operation.

1. SYSTEM SWITCH "ON"

The fresh air dampers open fully and once the fresh air damper end switch makes the supply fan starts and runs continuously. Unit operation is based on the supply air temperature and its setpoint. Unit will automatically operate in heating or eco mode to maintain the supply air temp setpoints. The supply air temperature setpoint is limited between 50°F and 90°F (10°C and 32.2°C).

Heating Operation

The outdoor air temperature must be below the Outdoor Air Heating Enable setpoint for the electric coil to be allowed to operate.

Heating is called when the fresh air temperature drops below the supply air temperature setpoint, or if the Heating Override is set to ON. The heating operation is controlled by a PID loop which will modulate the electric coil to maintain the supply air temperature setpoint.

Eco Operation

Whenever possible, the unit will operate without calling heating to maintain the supply air temperature setpoint. If the supply air temperature setpoint cannot be maintained, the unit will revert into heating mode.

2. SYSTEM SWITCH "OFF"

The unit is inoperative. The fresh air dampers are closed.

ADDITIONAL CONTROLS

Automatic Low Limit

If the supply air temperature falls below the low limit threshold of 40°F (4.4°C), the unit shuts down. A five minute time delay on unit start-up allows for a cold start.

High Limit Manual Reset

If the supply air temperature rises above the high limit threshold of 150°F (65.5°C), the unit shuts down. The unit requires a power cycle to resume normal operation.

BMS Points List

BACnet		Modbus			Variable	Units	Read / Write	Description
Instance	Type	Instance	Size	Type				
AI 1	Analog	0	2	InputRegister	FreshAirTemp	°F	Read Only	Measured temperature of outside/fresh air
AI101	Input	100	2		FreshAirTemp_C	°C		
AI 2	Analog	2	2	InputRegister	SupplyAirTemp	°F	Read Only	Measured Discharge/Supply air temperature
AI 102	Input	102	2		SupplyAirTemp_C	°C		
AI 3	Analog	4	2	InputRegister	ReturnAirTemp	°F	Read Only	Measured return air temperature
AI 103	Input	104	2		ReturnAirTemp_C	°C		
AI 4	Analog	6	2	InputRegister	MixedAirTemperature	°F	Read Only	Measured temperature after mixing fresh & return air
AI 104	Input	106			MixedAirTemperature_C	°C		
AI 5	Analog	8	2	InputRegister	EvaporatorLeavingAirTemp	°F	Read Only	(Reheated systems only) dewpoint of supply air
AI 105	Input	108			EvaporatorLeavingAirTemp_C	°C		
AI 6	Analog	10	2	InputRegister	ExhaustAirTemp	°F	Read Only	(Dual air path only) exhausted return air leaving temp
AI 106	Input	110			ExhaustAirTemp_C	°C		
AI 7	Analog	12	2	InputRegister	SpaceTemp	°F	Read Only	Measured Room / Space temperature
AI 107	Input	112			SpaceTemp_C	°C		
AI 10	Analog Input	18	2	InputRegister	SpaceCO2	PPM	Read Only	Measured Room / Space CO2 level in PPM
AI 11	Analog Input	20	2	InputRegister	SupplyCO	PPM	Read Only	Actual Discharge/Supply air carbon monoxide in PPM
AI 12	Analog Input	22	2	InputRegister	SupplyCO2	PPM	Read Only	Measured Supply / Discharge CO2 level in PPM
AI 20	Analog Input	38	2	InputRegister	FreshAirHumidity	%RH	Read Only	Measured RH of outside air
AI 21	Analog Input	40	2	InputRegister	SupplyAirHumidity	%RH	Read Only	Measured RH of supply/discharge air
AI 22	Analog Input	42	2	InputRegister	ReturnAirHumidity	%RH	Read Only	Measured RH of return air (room sample)
AI 23	Analog Input	44	2	InputRegister	MixedAirHumidity	%RH	Read Only	Measured RH of air after mixing fresh and supply air
AI 24	Analog Input	46	2	InputRegister	SpaceHumidity	%RH	Read Only	Measured RH of room/space air
AI 30	Analog Input	58	2	InputRegister	FreshAirAirflow	CFM	Read Only	Measured CFM of fresh air path
AI 31	Analog Input	60	2	InputRegister	SupplyAirAirflow	CFM	Read Only	Measured CFM of supply / unit discharge
AI 32	Analog Input	62	2	InputRegister	ReturnAirAirflow	CFM	Read Only	Measured CFM of return air path
AI 33	Analog Input	64	2	InputRegister	SupplyDuctStaticPress	"WC	Read Only	Measured DSP of the supply duct
AI 34	Analog Input	66	2	InputRegister	ReturnDuctStaticPress	"WC	Read Only	Measured DSP of the return duct
AV 1	Analog Value	0	2	HoldingRegister	SP_SupplyAirTemp	°F	Commandable	Discharge/Supply Air Temperature setpoint in °F (or °C)
AV 101		100	2		SP_SupplyAirTemp_C	°C		
AV 2	Analog Value	2	2	HoldingRegister	SP_SpaceTemp	°F	Commandable	Room/Space temperature setpoint (for reset)
AV 102		102	2		SP_SpaceTemp_C	°C		
AV 3	Analog Value	4	2	HoldingRegister	SP_SpaceDewpoint	°F	Commandable	Room/Space dewpoint setpoint (max. target)
AV 103		104	2		SP_SpaceDewpoint_C	°C		
AV 4	Analog Value	6	2	HoldingRegister	SP_MaxFreshAirPcnt	%	Commandable	Maximum fresh air setpoint in %
AV 5	Analog Value	8	2	HoldingRegister	SP_MinFreshAirPcnt	%	Commandable	Minimum fresh air setpoint in %
AV 6	Analog Value	10	2	HoldingRegister	SP_SupplyFanSpeedPcnt	%	Commandable	Supply Fan Speed

Installation

BACnet		Modbus			Variable	Units	Read / Write	Description
Instance	Type	Instance	Size	Type				
AV 7	Analog Value	12	2	HoldingRegister	SP_ReturnFanSpeedPcnt	%	Commandable	Return Fan Speed
AV 8	Analog Value	14	2	HoldingRegister	SP_SupplyDuctStaticPress	"WC	Commandable	Target supply duct static pressure
AV 9	Analog Value	16	2	HoldingRegister	SP_ReturnDuctStaticPress	"WC	Commandable	Target return duct static pressure
AV 10	Analog Value	18	2	HoldingRegister	BMSRoomAirTemp	°C	Commandable	Space Temperature, if sensor by BMS
AV 11	Analog Value	20	2	HoldingRegister	BMSFreshAirTemp	°C	Commandable	Fresh Air Temperature, if sensor by BMS
AV 12	Analog Value	22	2	HoldingRegister	BMSRoomAirDewpoint	°C	Commandable	Room Air Dewpoint Temperature, if sensor by BMS
AV 13	Analog Value	24	2	HoldingRegister	SP_MixboxAirTemp	°F	Commandable	Mixbox Air Temperature setpoint in °F (or °C)
AV 113		124			SP_MixboxAirTemp_C	°C		
AV 14	Analog Value	26	2	HoldingRegister	SP_MaxReturnAirPcnt	%	Commandable	Maximum Return air setpoint in %
AV 15	Analog Value	28	2	HoldingRegister	SP_MinReturnAirPcnt	%	Commandable	Minimum Return air setpoint in %
AV 16	Analog Value	30	2	HoldingRegister	SP_CO2_Threshold	PPM	Commandable	Threshold for CO2 Logic to become active
AV 17	Analog Value	32	2	HoldingRegister	SP_CO2_FADemand	%	Commandable	Fresh Air Demand for CO2 logic
AV 18	Analog Value	34	2	HoldingRegister	SP_SupplyAirflowCFM	CFM	Commandable	Target supply airflow
AV 19	Analog Value	36	2	HoldingRegister	SP_ReturnAirflowCFM	CFM	Commandable	Target return airflow
AV 40	Analog Value	78	2	InputRegister	FreshAirPcnt	%	Read Only	Current Fresh air damper position
AV 41	Analog Value	80	2	InputRegister	ReturnAirPcnt	%	Read Only	Current Return air damper position
AV 42	Analog Value	82	2	InputRegister	HeatingDemand	%	Read Only	Current Heating Demand from Heating PID
AV 43	Analog Value	84	2	InputRegister	CoolingDemand	%	Read Only	Current Cooling Demand from Cooling PID
AV 44	Analog Value	86	2	InputRegister	HeatWheelDemand	%	Read Only	Current Commanded Heatwheel Speed
AV 45	Analog Value	88	2	InputRegister	CubeBypassDamperDemand	%	Read Only	Current Cube Bypass Damper position
AV 56	Analog Value	56	2	HoldingRegister	RegenCore. HeatRecoveryCycleTime	seconds	Commandable	Time in Second for one complete cycle (2 damper changes) in ER mode
IV 54	Integer Value	54	2	HoldingRegister	RegenCore. FreeCoolingCycleTime	minutes	Commandable	Time in Minute for one complete cycle (2 damper changes) in FC mode
IV 31	Integer Value	90	2	InputRegister	Num_Alarms		Read Only	Number of active alarms
IV 32	Integer Value	92	2	InputRegister	Num_Warnings		Read Only	Number of active warnings

Installation

BACnet		Modbus			Variable	Inactive Text	Active Text	Read / Write	Description
Instance	Type	Instance	Size	Type					
BV 1	Binary Value	0	1	Coil	Unit_Run	OFF	ON	Commandable	Unit Run Command
BV 2	Binary Value	1	1	Coil	AlrmResByBMS	-	Reset	Commandable	Toggle Point to Reset Active Alarms
BV 10	Binary Value	9	1	DiscreteInput	Unit_InAlarm	OK	InAlarm	Read Only	When true, unit has alarm but may still be operational
BV 11	Binary Value	10	1	DiscreteInput	Unit_SeriousAlarm	OK	InAlarm	Read Only	When true, unit has shutdown due to a serious alarm
BV 12	Binary Value	11	1	DiscreteInput	Dirty_FreshAir_Filter_Alm	Clean	Dirty	Read Only	Pressure drop on Fresh Air filter high
BV 13	Binary Value	12	1	DiscreteInput	Dirty_FreshAir_Prefilter_Alm	Clean	Dirty	Read Only	Pressure drop on Fresh Air prefilter high
BV 14	Binary Value	13	1	DiscreteInput	Dirty_ReturnAir_Filter_Alm	Clean	Dirty	Read Only	Pressure drop on Return Air filter high
BV 15	Binary Value	14	1	DiscreteInput	Dirty_ReturnAir_Prefilter_Alm	Clean	Dirty	Read Only	Pressure drop on Return Air prefilter high
BV 21	Binary Value	20	1	DiscreteInput	Cooling_CircA_Fault	OK	FAULT	Read Only	Cooling Circuit A has a fault
BV 22	Binary Value	21	1	DiscreteInput	Cooling_CircB_Fault	OK	FAULT	Read Only	Cooling Circuit B has a fault
BV 23	Binary Value	22	1	DiscreteInput	Cooling_CircC_Fault	OK	FAULT	Read Only	Cooling Circuit C has a fault
BV 24	Binary Value	23	1	DiscreteInput	Cooling_CircD_Fault	OK	FAULT	Read Only	Cooling Circuit D has a fault
BV 30	Binary Value	30	1	DiscreteInput	Compressor_A1_Running	OFF	ON	Read Only	Compressor 1 of circuit A is running
BV 31	Binary Value	31	1	DiscreteInput	Compressor_A2_Running	OFF	ON	Read Only	Compressor 2 of circuit A is running
BV 32	Binary Value	32	1	DiscreteInput	Compressor_B1_Running	OFF	ON	Read Only	Compressor 1 of circuit B is running
BV 33	Binary Value	33	1	DiscreteInput	Compressor_B2_Running	OFF	ON	Read Only	Compressor 2 of circuit B is running
BV 34	Binary Value	34	1	DiscreteInput	Compressor_C1_Running	OFF	ON	Read Only	Compressor 1 of circuit C is running
BV 35	Binary Value	35	1	DiscreteInput	Compressor_C2_Running	OFF	ON	Read Only	Compressor 2 of circuit C is running
BV 36	Binary Value	36	1	DiscreteInput	Compressor_D1_Running	OFF	ON	Read Only	Compressor 1 of circuit D is running
BV 37	Binary Value	37	1	DiscreteInput	Compressor_D2_Running	OFF	ON	Read Only	Compressor 2 of circuit D is running
BV 50	Binary Value	50	1	DiscreteInput	Heat1_Running	OFF	ON	Read Only	Stage 1 Heat Running
BV 51	Binary Value	51	1	DiscreteInput	Heat2_Running	OFF	ON	Read Only	Stage 2 Heat Running
BV 52	Binary Value	52	1	DiscreteInput	Heat3_Running	OFF	ON	Read Only	Stage 3 Heat Running
BV 53	Binary Value	53	1	DiscreteInput	Heat4_Running	OFF	ON	Read Only	Stage 4 Heat Running
BV 54	Binary Value	54	1	DiscreteInput	SupplyFanCSR	OFF	ON	Read Only	Status of Supply Fan Current Sense Relay
BV 55	Binary Value	55	1	DiscreteInput	ReturnFanCSR	OFF	ON	Read Only	Status of Return Fan Current Sense Relay

Installation

BACnet		Modbus			Variable	Read / Write	Description
Instance	Type	Instance	Size	Type			
MSV 1	Multistate Value	1000	1	HoldingRegister	Unit_Mode_Override <i>Unit_Mode_Override_Default</i>	Commandable <i>RelinquishDefault</i>	Set to force unit into the following modes: 1=Auto (Normal) 2=ForceDehum 3=ForceEcono 4=ForceHeating 5=ForceCooling 6..9=Reserved 10=ForceOff
MSV 2	Multistate Value	1000	1	InputRegister	Unit_Status	Read Only	Unit Status: 1=Unit On 2=Off due to alarm 3=Off due to BMS 4=Off due to Schedule 5=Off due to System Switch 6=Off due to Keypad Enable 7=Off due to Interlock 8=Manual Mode 9=Unit in Startup Sequence
MSV 3	Multistate Value	1001	1	InputRegister	Unit_SystemStatus	Read Only	Unit mode enumeration: 1=Unit Off 2=Dehum 3=Econo 4=Heating 5=Cooling 6=Burner Warmup 7=Burner Cooldown 8=Damper Opening 9=Smoke Purge Sequence
MSV 11	Multistate Value	1010	1	HoldingRegister	PRC_DamperMode_Override_BMS	Commandable	Set to force unit into the following modes: 1=Auto (Normal) 2=ForceEnergyRecovery 3=ForceFreeCooling 4=ForceRecirculation 5+=ForceOff Dampers Only (Fans ON, TEST ONLY)
MSV 13	Multistate Value	1010	1	InputRegister	PRC_DamperMode_Status	Read Only	RegenCore Damper Status: 1=Off 2=EnergyRecovery 3=FreeCooling 4=Recirculation 5=SmokePurge

Maintenance

Maintenance



HAZARDOUS SERVICE PROCEDURES: During installation, testing, servicing and troubleshooting of this product, it may be necessary to work with live electrical components and moving mechanical components. Have a qualified technician who has been properly trained in handling live electrical components perform these tasks. Failure to follow all electrical safety precautions when exposed to live electrical and mechanical components could result in death or serious injury.

Regular maintenance is the best way to avoid untimely and expensive repairs, and it extends the useful life of the equipment. Maintenance should only be performed by qualified service personnel familiar with air handling equipment and local codes and requirements.

Maintenance Checklist	Quarterly	Annually
General Maintenance		
Inspect inside of unit for water leaks, foreign material etc.	X	
Clean or replace filters with equivalent to those supplied by manufacturer.	X	
Check cooling device drain pans and traps for cleanliness and blockage.	X	
Check all dampers, linkages and damper actuators and adjust and tighten as required.	X	
Check cooling or heating coils for cleanliness and clean as necessary.		X
Coil Winterization (Autumn)		X
Inspect and clean the control cabinet fan filters and heaters.		X
Inspect and clean any hood screens and filters.		X
Fan Maintenance		
Check all belts. Tighten or replace as necessary.	X	
Check sheave alignment. Adjust as necessary.	X	
Check all bearings and lubricate as necessary.	X	
Inspect fan wheel and housing. Clean as necessary.		X
Check condition of condenser fan blades.		X
Electrical Maintenance		
Check for loose wire connections in control panel.	X	
Check motor amp draw against name plate.	X	
Inspect all contactors to ensure they are clean and making good contact.	X	
Check all safeties.	X	
Electric Heat Maintenance		
Verify heating coil is clean, free of dust or lint. (Fall)		X
Inspect the heating coil for any indication of an overheating condition as well as any trace of rust.		X
Verify the resistance of each heating coil circuit against ground.		X

Maintenance

Coil Winterization

NOTICE - IMPROPER FREEZE PROTECTION CAN LEAD TO UNIT AND BUILDING DAMAGE: In climates where freezing conditions occur, some form of freeze protection must be followed to avoid coil damage and subsequent leaks that can damage the unit and the building. Damage from improper freeze protection will void the warranty.

In climates where freezing conditions may occur, some form of freeze protection for water coils is required. Coils can be drained and blown out with compressed air to ensure no water remains. Alternatively, some form of antifreeze rated for the expected ambient temperatures can be used. Antifreeze reduces the coil performance. If the coil was not designed for antifreeze, some amount of coil performance loss can be expected.

Service and Warranty Procedure

Replacement Parts

Replacement parts can be obtained from SolutionAir at mech-parts@solutionairgroup.com or 1-866-797-0760. When contacting SolutionAir for replacement parts, refer to the model number and serial number on the name plate.

Warranty Parts

See limited warranty below for what is covered. Contact SolutionAir at mech-parts@solutionairgroup.com or 1-866-797-0760 for warranty parts instructions. Have the unit model number and serial number available. The warranty part may need to be returned to SolutionAir to obtain a new warranty part. SolutionAir reserves the right to repair or replace a part under warranty.



AW-A START-UP REPORT

To enable the Limited Warranty, this form must be submitted to mechsupport@solutionairgroup.com

General

Job Name

Order Number

Installation Address

City

State/Prov.

Name of Person performing Start-up

Start-up Date

Service Company Name

Service Company Phone Number

Unit Information

Unit Model Number

Serial Number

Nameplate Rating (volt/phase/frequency)

INSTRUCTIONS: Check off boxes (Yes, No, N/A). Not all units contain each option listed in this form. Check off N/A if the statement/question is not relevant to this product. Fill in blank spaces with required information, when applicable. If the statement/question is not relevant to this unit, mark N/A in the blank space.

Please make note of any issues that you encounter in the inside the "Comments" section.

**CAUTION: High voltage may be present.
Disconnect all power supplies prior to performing initial inspection.**

AW-A START-UP REPORT

To enable the Limited Warranty, this form must be submitted to mechsupport@solutionairgroup.com

Initial Inspection

Exterior – look for damage to housing, doors, handles, fittings, etc. If damaged indicate where below.

Yes No _____

Interior – look for damage to housing, doors, handles, fittings, etc. If damaged indicate where below.

Yes No _____

Check that all ducts and dampers are secure	Yes	No	N/A
Check that all penetrations and openings are sealed	Yes	No	N/A
Remove all foreign material from unit	Yes	No	N/A
Are all shipping brackets removed?	Yes	No	N/A
Check and tighten any loose fasteners	Yes	No	N/A
Check and tighten all set screws, lock collars for all bearings, motors, dampers, etc.	Yes	No	N/A
Check all electrical connections and tighten any loose connections	Yes	No	N/A
Check and tighten all unit terminal strips	Yes	No	N/A
Are disconnects and fuses properly sized?	Yes	No	N/A
Does the disconnect mechanism function properly?	Yes	No	N/A
Do mechanical interlocks function properly?	Yes	No	N/A
Is drain pipe trapped properly?	Yes	No	N/A
Is gas piping installed correctly?	Yes	No	N/A

Fan Start-Up

Are fan shipping brackets removed? (3 per fan)	Yes	No	N/A
Do fans rotate freely?	Yes	No	N/A
Are fan pulleys aligned?	Yes	No	N/A
Are belts properly tensioned?	Yes	No	N/A
Is fan rotation correct?	Yes	No	N/A

Fans	Current @ 100% airflow			Voltage @ 100% airflow			Motor FLA	RPM
	L1	L2	L3	1-2	2-3	3-1		
Supply 1								
Supply 2								
Return 1								
Return 2								
Exhaust 1								
Exhaust 2								

AW-A START-UP REPORT

To enable the Limited Warranty, this form must be submitted to mechsupport@solutionairgroup.com

Controls

Are remote sensors and controls installed? Yes No N/A

Is there BAS connection? List the type of connection below. Yes No N/A

Time clock operation verified? Yes No N/A

Mixed air control operation verified? Yes No N/A

Filter gauge operation verified? Yes No N/A

Low limit setpoint (°F) High limit setpoint (°F) Discharge temp. setpoint (°F) Space temp. setpoint (°F)

Minimum fresh air setpoint (%) Filter gauge range Occupied time Unoccupied time

Dampers

Verify proper wiring for motorized dampers Yes No N/A

Check that all dampers open and close properly Yes No N/A

Check that all dampers have seals and shut tight Yes No N/A

Electric Heat

Is there any physical damage to the electric coil(s)? Yes No N/A

Is disconnect switch and/or fuses installed? Yes No N/A

Does electrical service correspond to nameplate? Yes No N/A

Check and tighten electrical connections Yes No N/A

Airflow proving switch setup and verified? Yes No N/A

Staging function verified? Yes No N/A

High limit control verified? Yes No N/A

Electric Heat Performance Measurements

Stage	Current			Voltage		
	L1	L2	L3	1-2	2-3	3-1
1						
2						
3						
4						
5						
6						

AW-A START-UP REPORT

To enable the Limited Warranty, this form must be submitted to mechsupport@solutionairgroup.com

Chilled Water

Is there any physical damage to the water coil(s)?	Yes	No	N/A
Coil piped for proper flow orientation?	Yes	No	N/A
Coil and pipes pressure tested and leak free?	Yes	No	N/A
Does the drain pan drain properly?	Yes	No	N/A
Fluid type (%/%)	_____		

Chilled Water Performance Measurements

_____	_____	_____
Airflow (CFM)	Fluid flow rate (SFPM)	Coil entering air temperature (°F)
_____	_____	_____
Fluid entering temperature (°F)	Coil leaving air temperature (°F)	Fluid leaving temperature (°F)

Hot Water

Is there any physical damage to the water coil(s)?	Yes	No	N/A
Coil piped for proper flow orientation?	Yes	No	N/A
Coil and pipes pressure tested and leak free?	Yes	No	N/A
Does the drain pan drain properly?	Yes	No	N/A
Fluid type (%/%)	_____		

Hot Water Performance Measurements

_____	_____	_____
Airflow (CFM)	Fluid flow rate (SFPM)	Coil entering air temperature (°F)
_____	_____	_____
Fluid entering temperature (°F)	Coil leaving air temperature (°F)	Fluid leaving temperature (°F)

Energy Wheel

Is there any physical damage to the energy wheel(s)?	Yes	No	N/A
Does the wheel rotate freely?	Yes	No	N/A
Wheel rotation direction verified?	Yes	No	N/A
Is drain properly connected?	Yes	No	N/A
Is VFD operating properly?	Yes	No	N/A
Wheel rotation speed (RPM)	_____		

AW-A START-UP REPORT

To enable the Limited Warranty, this form must be submitted to mechsupport@solutionairgroup.com

DX Cooling

Is there any visible damage to evaporator and/or condenser coil(s)?	Yes	No	N/A
Are all compressor shipping brackets removed?	Yes	No	N/A
Does the drain pan drain properly?	Yes	No	N/A
Does the condenser fan(s) rotate freely?	Yes	No	N/A
Verify proper condenser fan rotation	Yes	No	N/A
Verify proper compressor rotation	Yes	No	N/A

Remote Condenser Only (For Installing Contractor)

Were all the refrigerant circuit's pressure tested and leak free?	Yes	No	N/A
Were all the refrigerant circuits evacuated to below 500 microns?	Yes	No	N/A

DX Cooling Performance Measurements

Outdoor DB air temperature (°F)

Outdoor WB air temperature (°F)

Let the cooling system run at 100% cooling demand (all stages on) for 15 minutes to achieve steady state prior to taking readings for refrigerant circuits, compressors, and condenser fans.

Refrigerant Circuit	Suction Pressure (psig)	Head Pressure (psig)	Subcool (°F)	Superheat (°F)	Total Ref. Charge Added or Removed (lb)
1					
2					
3					
4					
5					
6					

Compressor	Current			Voltage		
	L1	L2	L3	1-2	2-3	3-1
1						
2						
3						
4						
5						
6						

AW-A START-UP REPORT

To enable the Limited Warranty, this form must be submitted to mechsupport@solutionairgroup.com

Condenser Fan	Current			Voltage		
	L1	L2	L3	1-2	2-3	3-1
1						
2						
3						
4						
5						
6						

QUALITY ASSURANCE REPORT

Your opinion is important to us. Please take a moment to fill out this report and email it to mechsupport@solutionairgroup.com. We use this information to continuously improve our products and services. Please include pictures in your email submission of this report whenever possible.

General

Job Name: _____ Order Number: _____
Installation Address: _____
City: _____ State/Province: _____
Name of Service Tech performing Start-up: _____
Service Company Name: _____ Service Company Phone Number: _____
Serial Number: _____

Initial Inspection

Any visible damage?	Yes	No	N/A
Please describe the damage: _____			

Fan Start-Up

How is the overall fit and finish?	Needs Improvement	Satisfactory	Excellent
Were there any electrical or controls issues?	Yes	No	N/A
Please describe the issue: _____			
Were there any gas heat issues?	Yes	No	N/A
Please describe the issue: _____			
Were there any refrigeration system issues?	Yes	No	N/A
Please describe the issue: _____			
Were the schematics, manuals, labels etc. useful?	Yes	No	N/A
How could we make them better?: _____			

Additional comments and suggestion on how to improve our products and services



Limited Warranty

- (a) SolutionAir warrants and guarantees for a period limited to twelve (12) months from date of installation / commissioning or eighteen (18) from date of shipment - whichever comes first, that the Products are manufactured in accordance with SolutionAir's quotation and submittal drawing specifications and of specified material unless otherwise expressly stated.
- (b) SolutionAir will manufacture the goods to be supplied in accordance with the product specifications supplied by Purchaser. SolutionAir shall not be liable for any loss or damages of any kind resulting from errors, omissions or untimely notification of changes to the specifications that have been provided. In the event that changes to the product specifications arise, SolutionAir must be notified immediately and in writing. The Purchaser will assume liability for the cost of all material and resources, work-in-progress and finished goods that have become obsolete or that can no longer be used due to any such changes in the specifications supplied.
- (c) In the event the Products supplied do not comply with quotation and submittal drawing specifications and/or material quality standards within the warranty period, SolutionAir will either repair the Products supplied or provide replacement of such Products that conform to the quotation and submittal drawing specifications. This decision is made at the sole discretion of SolutionAir. In either case, SolutionAir will not be responsible for labor and freight charges incurred in replacing Products except as agreed to by SolutionAir in writing, nor will SolutionAir be responsible for incidental, consequential or punitive damages. In the event SolutionAir elects to repair the Products supplied, Purchaser will assist by providing SolutionAir with all details of the problem and a written quotation for the costs of such work to be carried out. If the repair is authorized by SolutionAir, then Purchaser will assist by coordinating and supervising the repair work. In the event SolutionAir elects to replace the Products, SolutionAir may either (i) direct the Purchaser to return such Products to SolutionAir or (ii) provide replacement Products to the Purchaser without the return of the original Products, in which case Purchaser will be responsible for the disposal of such original Products. Such election is at the sole discretion of SolutionAir, and all returns of Products to SolutionAir must be approved in advance by SolutionAir. In the event SolutionAir directs Purchaser to return the Products to SolutionAir for repair or replacement, Purchaser agrees to return such Products to SolutionAir in a manner consistent with the original packaging in order to prevent damage. All freight back to SolutionAir's factory and return freight to Purchaser must be agreed upon prior to return of the Products.
- (c) SolutionAir makes no warranty whatsoever with respect to components or items supplied which may be warranted separately by their manufacturer. SolutionAir does not warrant factory mounted controls and components of Products supplied and owned by a third party for mounting by SolutionAir. Back charges to SolutionAir for Products under warranty by others will only be accepted if prior written approval is given by SolutionAir.
- (d) THE WARRANTIES AND LIABILITIES SET FORTH IN THE PRIOR PARAGRAPHS ARE THE ONLY WARRANTIES OR LIABILITIES OF SOLUTIONAIR. ALL OTHER GUARANTEES, WARRANTS, CONDITIONS AND REPRESENTATIONS, EITHER EXPRESS OR IMPLIED, WHETHER ARISING UNDER ANY STATUTE, LAW, COMMERCIAL USAGE OR OTHERWISE, INCLUDING IMPLIED WARRANTIES FOR FITNESS OF MERCHANTABILITY AND FITNESS FOR A PARTICULAR PURPOSE, ARE HEREBY EXCLUDED.
- (e) The foregoing warranty shall not take effect unless Purchaser shall inform SolutionAir in writing of any flaw, defect or deficiency in the Products promptly after such flaw, defect or deficiency becomes apparent and, in any case, not later than one (1) year from date of shipment. The warranty provided for under these Terms shall be void upon the following: (i) the unauthorized repair or modification by any person other than SolutionAir of Products claimed to be defective; or (ii) the improper installation, maintenance or operation of the Products other than in strict accordance with standard industry practices and compliance with the specific recommendations of SolutionAir respecting the Products; or (iii) the misuse, negligence, or operation of the Products other than for their intended purpose.

The SolutionAir warranty is void if;

- 1. The unit is not installed and serviced in accordance with manufacturer's recommendations.**
- 2. Operation, maintenance, start-up and shut down are not in accordance with manufacturer's instructions.**
- 3. Unit is operated in conditions not specified by the manufacturer.**
- 4. The unit is operated while the building is under construction.**
- 5. Unit is used for application which it was not intended.**

Appendix A: Assembly of Split Units

Purpose

To provide an overview and basic understanding of the process for on-site assembly of split air handling units.

Installer Supplied Tools and Material

- Exterior-grade caulking
- Rigging equipment sufficiently rated for the weights being hoisted
- Sufficiently long threaded rod, nuts and bolts to pull sections together
- Soapy water to lubricate between the roof curb and unit base (if required)
- Come-alongs (only to be used on the base frame as needed)

Factory Supplied Material

- Neoprene gasket
- Roof caps
- Fasteners

Instructions

These instructions apply to both vertically and horizontally split units. All joining hardware is provided by SolutionAir and is shipped with the unit unless noted otherwise.

1. Ensure the bottom of the first section's base is clean and free from debris and place it on the roof curb, aligning all edges. Connect and tighten the fasteners holding the section to the roof curb if applicable.
2. Sections with 6-point lifts may have removable center lugs (Figure 1). They can be removed once the section is seated on the roof curb.

FIGURE 1: REMOVABLE CENTER LUG SHOWN ON BASE FRAME ▼



Appendices

3. Apply the supplied ¼" thick gasket material to one side of the open face, ensuring it is placed as shown in Figure 2 and that it is well adhered.
4. It is recommended to spray soapy-water on the entire roof curb prior to placing the subsequent sections. This will help with pulling the sections together.
5. Move the second section into place on the roof curb as close as possible but no more than 2" from the already anchored section (Figure 3). Once the second section is on the curb, the center lug can be removed.

FIGURE 2: GASKET APPLIED TO THE PERIMETER OF THE OPENING ▼



FIGURE 3: SECOND SECTION PLACED WITHIN 2" OF THE ANCHORED SECTION ▼

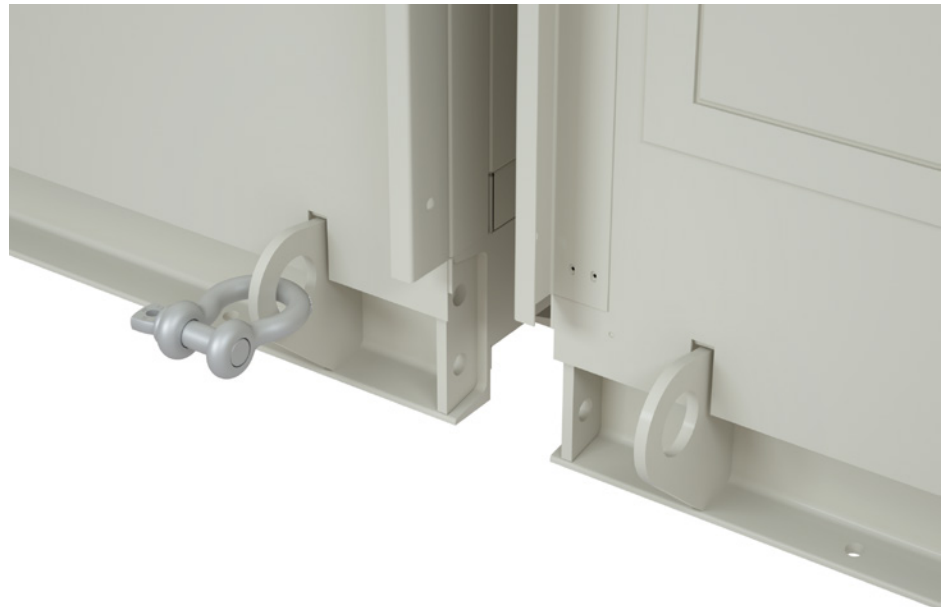

Appendices

6. Use threaded rod, washers and nuts to slowly, and evenly pull Section 2 towards Section 1 from the base (Figure 4). Once the base is tight, verify that the gasket around the walls and roof splits is still in place and has not been damaged during the pull-in procedure.
7. The bases then need to be secured to one another (Figure 5), and then to the roof curb.
8. Once the bases are bolted together, the connecting flanges must be secured to one another using the supplied fasteners.

FIGURE 4: THREADED ROD, WASHERS AND NUTS FOR PULLING SECTIONS TOGETHER ▼

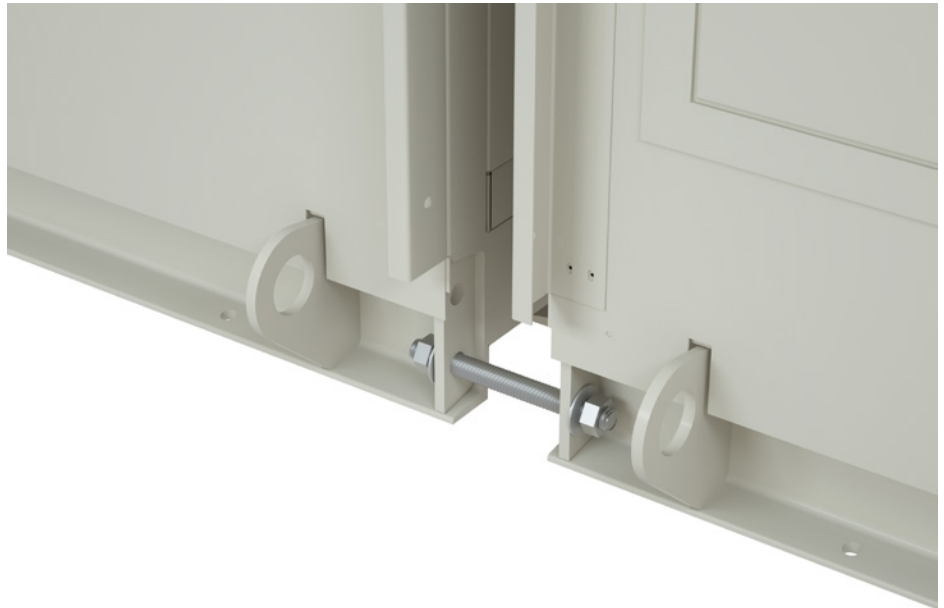

FIGURE 5: BOLTS, WASHERS AND NUTS USED TO FASTEN THE BASE TOGETHER ▼



Appendices

9. A bead of silicone caulking must then be run across the top of the bolting flange and down the side. If the roof is split, use the supplied roof cap to cover the joint shown in Figure 6.
10. Repeat steps 1 through 9 for all sections of the split air handler unit until all sections are joined.
11. Install all loose exterior features, which may include hood assemblies, exhaust flues and field sensors. Field sensors should be wired according to the supplied electrical diagram.

FIGURE 6: ROOF CAP INSTALLED TO COVER JOINTS AT SPLIT ▼



Appendices

12. All high voltage wiring (such as fans, motors, blowers, compressors, etc.) is spooled by the factory and is to be pulled through the air handler unit upon assembly (Figure 7). Wires should be connected to the corresponding labeled terminals.
13. All low voltage control wiring (such as actuators, sensors, etc) is disconnected at the air handler unit splits. Spade connectors or junction boxes containing terminal blocks are installed at the splits. All control wiring and terminals are marked to aid with on-site assembly.
14. The unit is now ready to be connected to the main power source. This operation must be performed by a qualified electrician and done according to local codes and regulations.

FIGURE 7: HIGH VOLTAGE WIRES SPOOLED ▼





This document contains the most current product information as of this printing.
For the most up-to-date product information, please go to SolutionAirGroup.com

© 2021 SolutionAir Group. All rights reserved.